

FRY TOP S Electric M80 AISI plate - smooth - on thermostatically controlled compartment

CODICE
CR1652539T4W

MODELLO
DT94/10SFTEA-T4W

SERIE
DIAMANTE 4.0



GENERAL CHARACTERISTICS

Diamond 90 Touch 4.0 - Everything under control Everything is under control, perfect results every time. Thanks to the practical display, parameter selection is quick and precise. Easy and clear temperature management, and special functions are always visible and accessible from the display. Tradition and innovation, everything on your worktop A new non-slip square and rounded knob design for a more ergonomic grip and an embossed indicator that makes it easier to select the datum to be set. And with the exclusive Encoder Functionality, simply touch the parameter you want, turn the knob to adjust the level and press it to start the set datum. With water- and dirt-proof crown. Quick and precise parameter selection. Easy and clear temperature management. Special functions always visible and accessible from the display. Stainless steel outer shells and feet. Height from worktop adjustable from 840 to 900 mm. Tops with 2 mm thickness All model-identified equipment (T4W) is 4.0 Ready equipment, allowing you to benefit from all the advantages of connecting your equipment to a cloud system.

TECHNICAL SPECIFICATIONS

- Cooking plate lowered from the top by 40 mm. ■ Cooking plates made with a satin-finished surface and coated with soft iron or polished hard chrome, all available in smooth, mixed or ribbed versions. ■ Plates inclined by 10mm towards the front of the machine. ■ Large grease collection drawer. ■ Dimensions: 40, 60, 80, ■ Heating by means of armoured incoloy heating elements. ■ Thermostatically controlled and adjustable baking temperature from 110 to 280°C. ■ Safety thermostat. ■ Electric version: heating by means of armoured incoloy heating elements. Cooking temperature thermostatically controlled and adjustable from 110 to 280°C. Safety thermostat.

- Floodable gutter for collecting cooking residues around the perimeter of the cooking plate easier cleaning and better retention of moisture in cooking food ■ Large fat collection drawer with capacity of the entire volume of the perimeter channel ■ Grooved plate design ensures cleanliness right to the end of the plate ■ Plate not welded to the machine bed with optimisation of structural points under thermal stress ■ Plate not welded to the machine bed with optimisation of structural points under thermal stress ■ Thermal cutting that facilitates the user and adjacent machinery. ■ Uniform cooking temperature across the entire plate. Optimising heat in the cooking area and increasing operator comfort in the kitchen. ■ Water dispenser kit available as an accessory

FRY TOP S Electric M80 AISI plate - smooth - on thermostatically controlled compartment

CODICE
CR1652539T4W

MODELLO
DT94/10SFTEA-T4W

SERIE
DIAMANTE 4.0

Technical Information

SPECIFICATION	DATA
MATERIAL	CR1652539T4W
DEFINITION	DT94/10SFTEA-T4W FTE LISCIO 430 M80 A/G
COMMERCIAL LINE	DIAMANTE
SUPPLY	ELECTRICS
DIM. WIDTH	800 mm
DIM. PRODUCTIVITY	900 mm
DIM. HEIGHT	870 mm
NET WEIGHT	113 Kg
VOLUME (net)	0.626
PACKAGE LENGTH	840 mm
PACKAGE WIDTH	850 mm
PACKAGING HEIGHT	1170 mm
PACKAGE VOLUME	0,836 m3
GROSS PACKING WEIGHT	128 Kg
STANDARD POWER SUPPLY	380-415V 3N
FREQUENCY	50-60 Hz
ELECTRICAL POWER	15 kW
IP GRADE	IPX5
CERTIFIED MODEL	D94/10SFTEA

FRY TOP S Electric M80 AISI plate - smooth - on thermostatically controlled compartment



weinnovate cooking

CODICE
CR1652539T4W

MODELLO
DT94/10SFTEA-T4W

SERIE
DIAMANTE 4.0

MISURE IN cm - DIMENSIONS IN cm - ABMESSUNGEN IN cm- MESURES EN cm
MEDIDAS EN cm - MATEN IN cm - DIMENSIONES EN cm

D92/10STFTE..

D93/10STFTE..

D94/10STFTE..

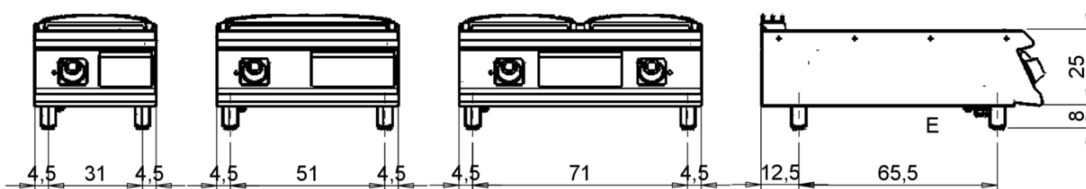

D92/10SFTE..

D93/10SFTE..

D94/10SFTE..

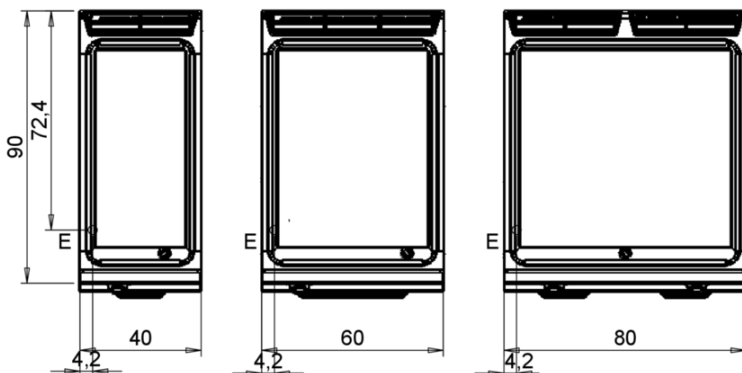
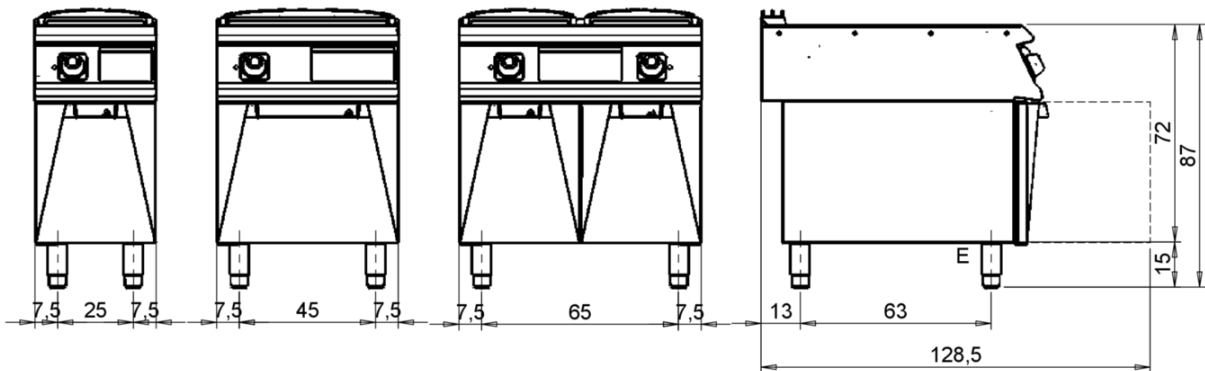

Legenda - Legende - Key - Légende - Leyenda - Legenda - Legenda

E Pressacavo entrata linea elettrica - Stopfbuchse - Electric cable stress relief - Presse étoupe de câble él - Pisacable - Elektrische kabelwartel - Entrada cabo eléctrico	G Arrivo gas - Gasanschluss - Gas connection - Arrivée gaz - Union de gas - Gasaansluiting - Ligação gás
S Attacco scarico acqua - Wasserablauf - Water outlet - Vidange de l'eau - Desaguadero - Wateraftapaansluiting - Junção descarga água	H20 Arrivo acqua - Wasseranschluss - Water inlet - Arrivée eau - Union de agua - Wateraansluiting - Junção alimentação água
S1 Scarico vasca - Wannenabflussrohr - Pan outlet - Vidange du bac - Descarga cuba - Water toevoer - Descarga da cuba	A1 = Calda - Heiss - Warm - Chaud - Caliente - Warm - Morno A2 = Fredda - Kalt - Cold - Froid - Fria - Koude - Frio
S2 Valvola di depressione - Anti-depression valve - Unterdruck ventil - Soupape de dépression - Válvula de depésión - Onderdrukklep - Válvula de depressão	
S3 Scarico acqua intercapedine - Wasserablauf Zwischenraum - Jacket water drain Evacuation eau double envelope - Descarga de agua intersticios - Afvoer water tussenruimte - Descarga de água na marmita com Sistema de aquecimento indirecto	
S4 Scarico - Abflussrohr - Drain - Tuyau d'évacuation - Tubo de drenaje - Aftapbuis - Tubulação de dreno	L Rubinetto di livello - Level tap - Wasserhahn - Robinet de niveau - Grifo de nivel - Niveaakraan - Torneira de nível



Olis Ali Group S.r.l.
Via Del Boscon, 424 - 32100 Belluno - Italy
Web: olis.it - Mail: info@olis.it

FRY TOP S Electric M80 AISI plate - smooth - on thermostatically controlled compartment

CODICE
CR1652539T4W

MODELLO
DT94/10SFTEA-T4W

SERIE
DIAMANTE 4.0



Floodable gutter for collecting cooking residues around the perimeter of the cooking plate easier cleaning and better retention of moisture in cooking food

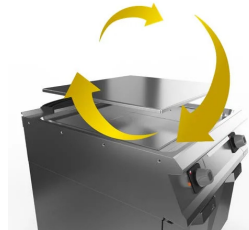

Plate not welded to the machine bed with optimisation of structural points under thermal stress



Floodable gutter for collecting cooking residues around the perimeter of the cooking plate easier cleaning and better retention of moisture in cooking food

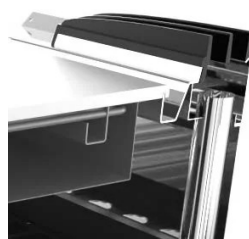
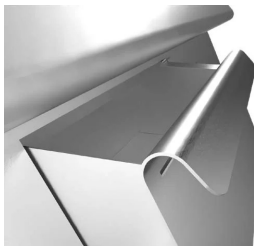
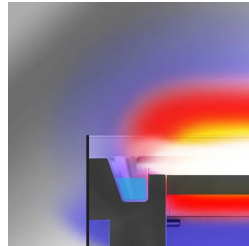

Plate not welded to the machine bed with optimisation of structural points under thermal stress



Large fat collection drawer with capacity of the entire volume of the perimeter channel



Thermal cutting that facilitates the user and adjacent machinery.



Grooved plate design ensures cleanliness right to the end of the plate

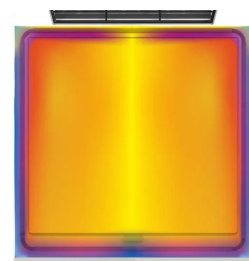

Uniform cooking temperature across the entire plate. Optimising heat in the cooking area and increasing operator comfort in the kitchen.

FRY TOP S Electric M80 AISI plate - smooth - on thermostatically controlled compartment

CODICE
CR1652539T4W

MODELLO
DT94/10SFTEA-T4W

SERIE
DIAMANTE 4.0

ACCESSORIES

CODE	MODELLO	DESCRIZIONE
CR1357499	4.0IOTPRO	PRO Subscription - Cloud
CR1357479	4.0IOTENTRY	ENTRY Subscription - Cloud
CR1354989	PRPC	Smooth plate cleaning scraper - chrome-plated
CR1356399	RPR	Striped chrome plate scraper
CR1658629	D97CPFT68	Fry top cleaning drawer M60 - M80
CR1658609	97TFT	Plancha cleaning cap
CR1354999	PKLR	Replacement blades (10PCS)
CR1658689	9AFT8	M80 splash guard
CR1658709	D7968CAFT	WATER LOADING FOR FRY TOP M60 M80 - D70 D90 - GAS OR ELECTRIC
CR1658799	D98EKSCFT	CONTINUOUS DISCHARGE FOR FRY TOP M80 - D90 - ELECTRIC
CR1658829	D98ECSCFT	LOAD + SCAR.CONTINUOUS FOR FRY TOP M80 - D90 - ELECTRIC